

# DESIGN NOTES

## Video Circuits Collection – Design Note 57

William H. Gross

### Introduction

This note shows how to make several different video circuits using high speed op amps. All of these circuits work with composite, RGB and monochrome video. For best results, bypass the power supply pins of these amplifiers with  $1\mu\text{F}$  to  $10\mu\text{F}$  tantalum capacitors in parallel with  $0.01\mu\text{F}$  disc capacitors. It is important to terminate both ends of video cables to preserve frequency response. When properly terminated, the cable looks like a resistive load of  $150\Omega$ .

### Lots of Inputs Video MUX Cable Driver (LT1227)

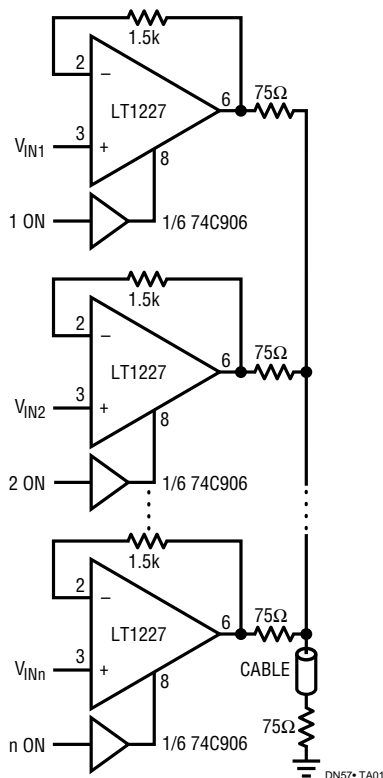

### Multiplex Amplifiers

Often it is desirable to select one of several signals to send down a cable. Connecting the outputs of several amplifiers together and using the amplifier's shutdown pin to disable all but one accomplishes this goal. The LT1190, LT1191, LT1192, and LT1193 are shutdown by pulling pin 5 to the negative supply.

The LT1223 and LT1227 current feedback amplifiers are shutdown by pulling pin 8 to ground. During normal operation pin 8 is open and at the positive supply potential. An easy way to interface pin 8 to logic is with a logic level N-Channel FET or a 74C906 (open drain hex buffer).

### Two Input Video MUX Cable Driver (LT1190)

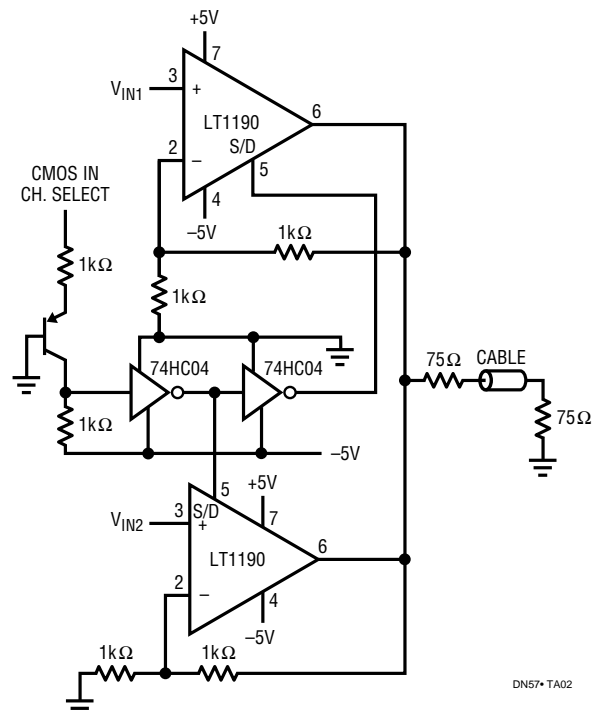

### Differential Gain and Phase of Several Amplifiers

PART NO.	DIFFERENTIAL			
	LOAD = 1kΩ		LOAD = 150Ω	
	GAIN	PHASE	GAIN	PHASE
LT1190*	0.05	0.02	0.23	0.16
LT1191*	0.03	0.01	0.09	0.07
LT1192**	0.10	0.01	0.23	0.15
LT1193*	0.20	0.08	0.20	0.08
LT1194**	0.20	0.08	0.20	0.08
LT1223	0.01	0.02	0.12	0.26
LT1227	0.01	0.01	0.01	0.01
LT1228	0.01	0.01	0.04	0.10
LT1229	0.01	0.01	0.04	0.10

$V_S = \pm 15V, A_V = 2$

\*  $V_S = \pm 8V, A_V = 2$

\*\*  $V_S = \pm 8V, A_V = 10$

### Loop Through Cable Receivers

Most video instruments require high impedance differential input amplifiers that will not load the cable even when the power is off.

#### Differential Input Video Loop Through Amplifier Using a Video Difference Amplifier (LT1194)

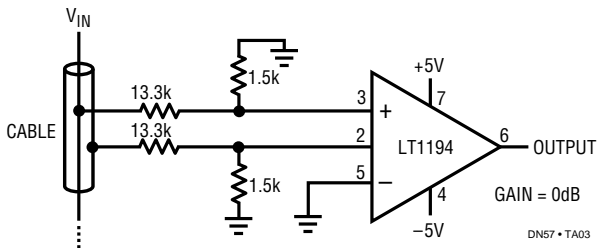

#### Electronically Controlled Gain, Video Loop Through Amplifier (LT1228)

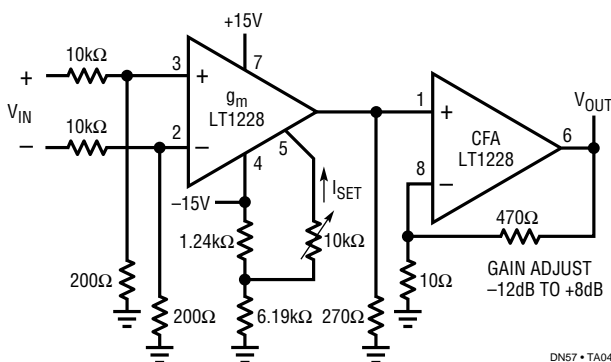

### DC Restore Circuits

The following circuit restores the black level of a monochrome composite video signal to 0V at the beginning of every horizontal line. This circuit is also used with CCD scanners to set the black level.

### Video DC Restore (Clamp) Circuit (LT1228)

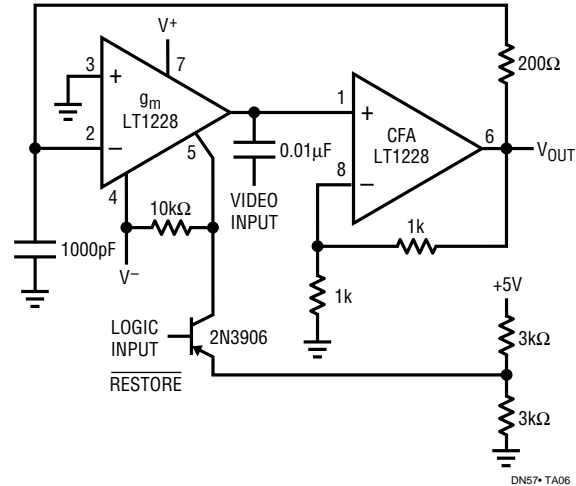

### Fader Circuits

Using two LT1228 transconductance amplifiers in front of a current feedback amplifier forms a video fader. The ratio of the set currents into pin 5 determines the ratio of the inputs at the output.

#### Video Fader (LT1228, LT1223)

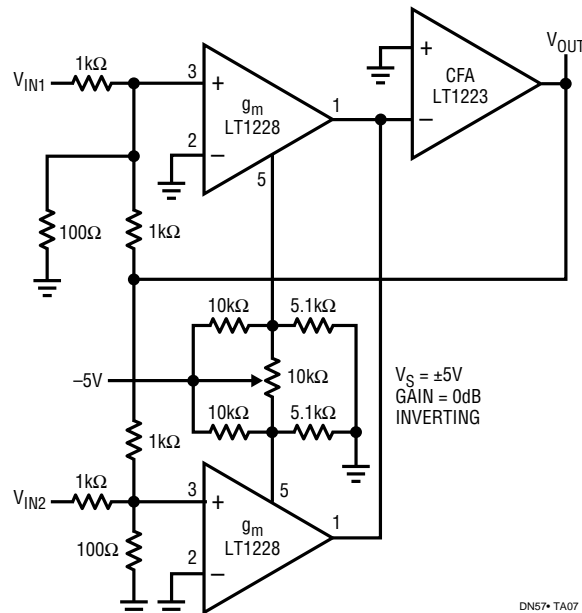

For literature on our High Speed Amplifiers, call (800) 637-5545. For applications help, call (408) 432-1900, Ext. 456

Linear Technology Corporation

1630 McCarthy Blvd., Milpitas, CA 95035-7487

(408) 432-1900 • FAX: (408) 434-0507 • TELEX: 499-3977

BA/GP 0292 190K

**LINEAR**  
TECHNOLOGY

© LINEAR TECHNOLOGY CORPORATION 1992